

# CLAMPJOB®



## 5-SHELF BOLTLESS SHELVING UNITS

MODEL NO: CSR5100

PART NO: SEE TABLE PAGE 2

## ASSEMBLY INSTRUCTIONS



GC0416

---

## INTRODUCTION

---

Thank you for purchasing this CLARKE Shelving Unit.

Before attempting to use this product, please read this manual thoroughly and follow the instructions carefully. In doing so you will ensure the safety of yourself and that of others around you, and you can look forward to your purchase giving you long and satisfactory service.

Please keep these instructions in a safe place for future reference.

---

## SCOPE

---

These instructions cover the following models

Description	Model	Part Number
5-Shelf 100kg Boltless Shelving (Light Grey)	CSR5100LG	6600686
5-Shelf 100kg Boltless Shelving (Blue)	CSR5100BL	6600688
5-Shelf 100kg Boltless Shelving (Red)	CSR5100RP	6600690

---

## SPECIFICATIONS

---

Model	Dimensions (W x D x H)	Weight (Empty)	Load per shelf (evenly distributed)
All CSR5100 Units	900 x 400 x 1800 mm	16.9 kg	100 kg

# INVENTORY

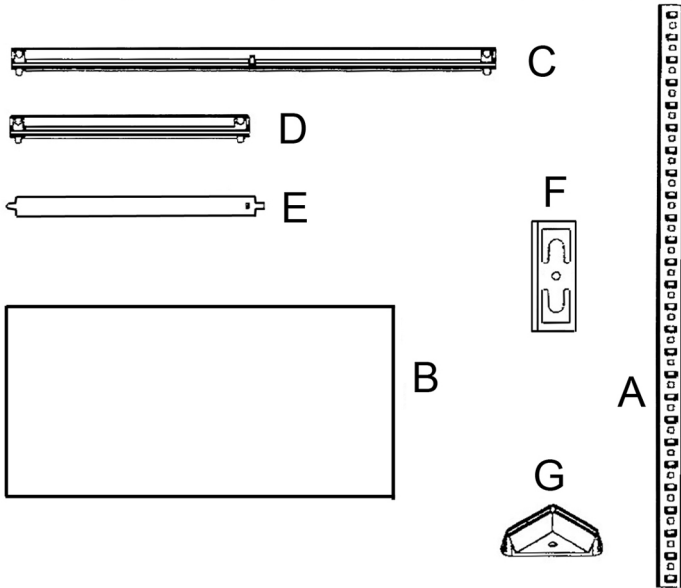

No	Description	Quantity
A	Corner Post	8
B	Shelf	5
C	Long Beam	10
D	Short Beam	10
E	Centre Beam	5
F	Post Joining Insert	4
G	Plastic End Cap	8

---

## ASSEMBLY ADVICE

---

1. Assemble on a strong, level surface. Avoid assembly on a domestic carpet.
  2. Use a cloth or softwood block to protect the surface finish of the product when using a mallet. Strike the flat surface of each beam to prevent damage to the beam.
  3. Always ensure that the rivets sit at the bottom of the keyhole slots.
  4. It is recommended that the assembly should be done by two persons.
  5. Always wear protective gloves when assembling the shelving unit.
  6. The shelving unit is not recommended for outdoor use.
- 

## ASSEMBLY INSTRUCTIONS

---

### TOOLS REQUIRED

- Rubber mallet or hammer
- Protective cloth/wood block

The tabs of the beams will often enter the slots fully using just firm hand pressure but if they are too tight, you may require a rubber mallet to assist. If so, always use a cloth to protect the product paint finish.

Tap gently with the mallet to drive the tabs of the beams fully into the slots in the post. Always strike the edge close to the post.

1. Use the short beams (D) to connect the front and rear posts together.

**NOTE:** The short and long beams should be installed with the recessed edge uppermost to retain the shelf.

- Repeat this again to create the other end assembly, making sure that the corresponding beams are at the same height.

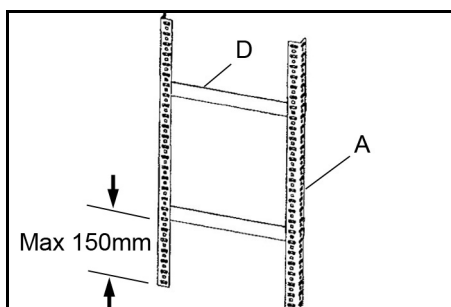
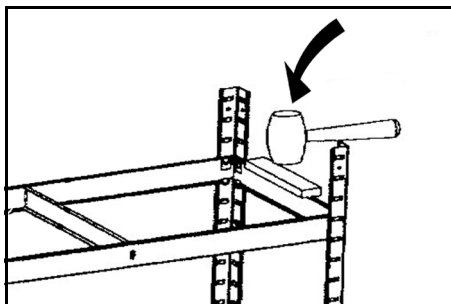

2. Ensure the tabs lie flat against the surface of the post.

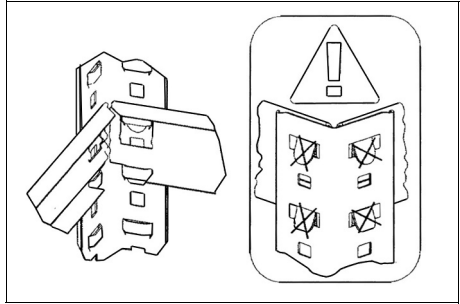

3. Join the two end assemblies together with the long beams (C).

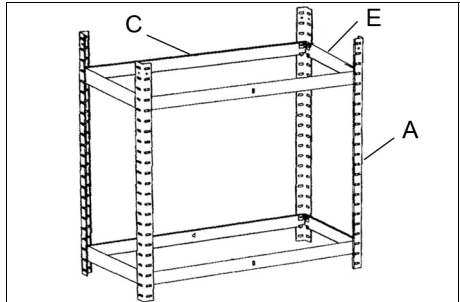

4. Connect the support beams (E) to the long beams (C). First bend the tabs 90 degrees to pass them through the slots in the long beams.

- The tab initially lays flat against the long beam (C).

5. Next, bend the tab back through 180 degrees to grip the long beam.

- Use a screwdriver or similar tool to bend the tabs.

6. Finally bend the tab again through 90 degrees the opposite way, to seat tightly against the support beam (E).

7. Ensure there is no movement between the beams.

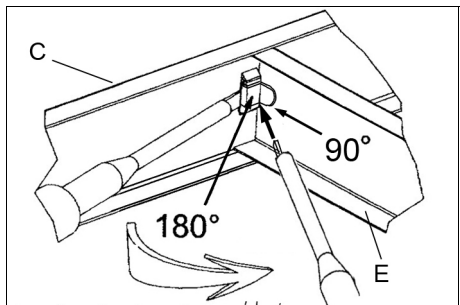
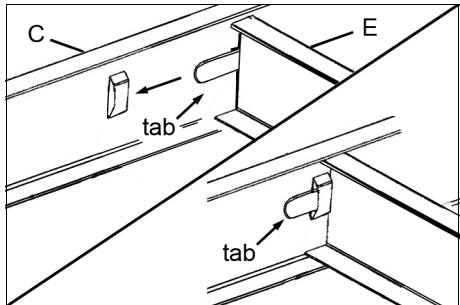

8. Fit post joining inserts (F) into the posts (A), ensuring that the inserts are fitted with their keyholes to match those of the posts.
9. Construct the upper end assemblies onto the post inserts (F) before adding more long beams and support beams as previously to complete the framework.

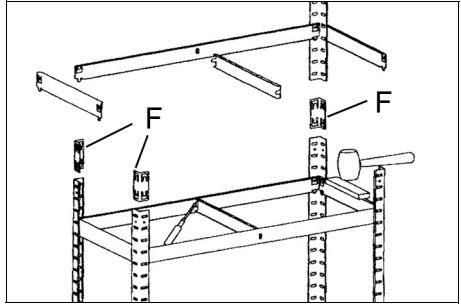

10. Lay the shelf panels (B) into position.

- Always assemble the top shelf at the highest possible position.

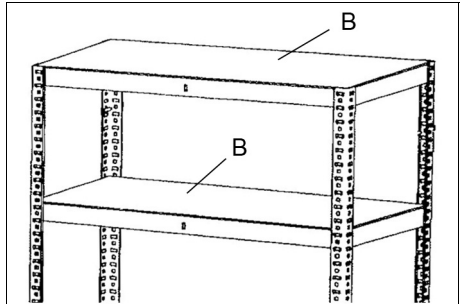

11. Insert the plastic end caps (G) into the end of each post (A).

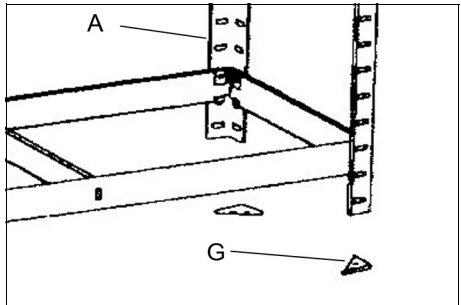

12. We recommend that the shelving be secured to an adjacent wall using typical wall insert plugs and screws (not supplied) aligned with the assembly slots in the posts.

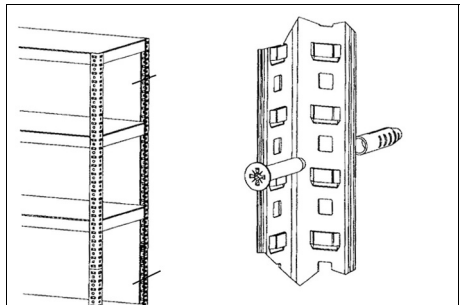

---

## **GENERAL SAFETY RULES**

---

1. Always maintain equipment in good condition for the best/safest performance.
2. Never exceed the maximum load for these shelving units as stated in the specification.
3. Never use these units if they are damaged.
4. Always load small, stable items on the top shelves, heavier and bulky items should be stored on the lower shelves.
5. Always distribute heavy loads evenly across the shelves.

---

## **GUARANTEE**

---

This product is guaranteed against faulty manufacture for a period of 12 months from the date of purchase. Please keep your receipt which will be required as proof of purchase.

This guarantee is invalid if the product is found to have been abused or tampered with in any way, or not used for the purpose for which it was intended.

Faulty goods should be returned to their place of purchase, no product can be returned to us without prior permission.

This guarantee does not effect your statutory rights.

---

## **ENVIRONMENTAL PROTECTION**

---

Do not dispose of old products or damaged parts with general household waste. All tools, accessories and packaging no longer required should be sorted, taken to a recycling centre and disposed of appropriately.

# A SELECTION FROM THE VAST RANGE OF

# Clarke®

## QUALITY PRODUCTS

### AIR COMPRESSORS

From DIY to industrial, Plus air tools, spray guns and accessories.

### GENERATORS

Prime duty or emergency standby for business, home and leisure.

### POWER WASHERS

Hot and cold, electric and engine driven - we have what you need

### WELDERS

Mig, Arc, Tig and Spot. From DIY to auto/industrial.

### METALWORKING

Drills, grinders and saws for DIY and professional use.

### WOODWORKING

Saws, sanders, lathes, mortisers and dust extraction.

### HYDRAULICS

Cranes, body repair kits, transmission jacks for all types of workshop use.

### WATER PUMPS

Submersible, electric and engine driven for DIY, agriculture and industry.

### POWERTOOLS

Angle grinders, cordless drill sets, saws and sanders.

### STARTERS/CHARGERS

All sizes for car and commercial use.



**PARTS & SERVICE: 0208 988 7400**

E-mail: [Parts@clarkeinternational.com](mailto:Parts@clarkeinternational.com) or [Service@clarkeinternational.com](mailto:Service@clarkeinternational.com)

**SALES: UK 01992 565333 or Export 00 44 (0)1992 565335**

**Clarke** INTERNATIONAL Hemnall Street, Epping, Essex CM16 4LG  
[www.clarkeinternational.com](http://www.clarkeinternational.com)